

# NO BEND WEED REMOVER

## CAUTION:

- **THIS ITEM IS NOT A TOY KEEP AWAY FROM CHILDREN.**
- **USE CARE TO PREVENT INJURY WHEN USING THE NO BEND WEED REMOVER. USE FOR REMOVING WEEDS ONLY.**
- **DO NOT USE THE ITEM TO LOOSEN DIRT.**

## USE INSTRUCTIONS:

For best results wet the soil before using the No Bend Weed Remover.

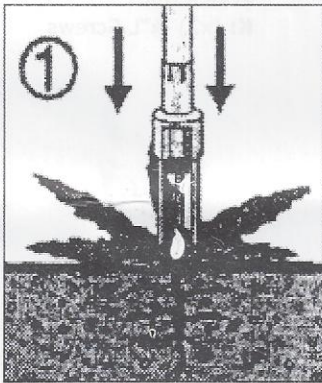

**STEP 1:** Center the 3 prongs over the weed and push downward firmly.

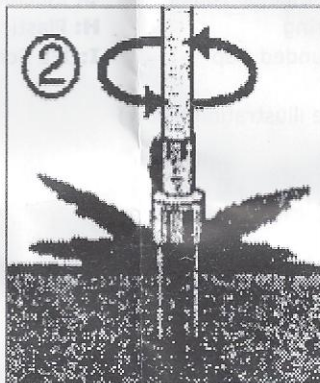

**STEP 2:** Turn the weed remover 360\* twice (for weeds with deep roots you may need a few extra turns).

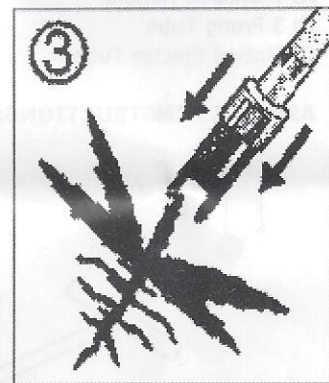

**STEP 3:** Push the ejector from the top of the t-shaped handle to remove the weed from the 3 prongs.

# NO BEND WEED REMOVER

**PARTS:** (Phillip screw driver required for assembly.)

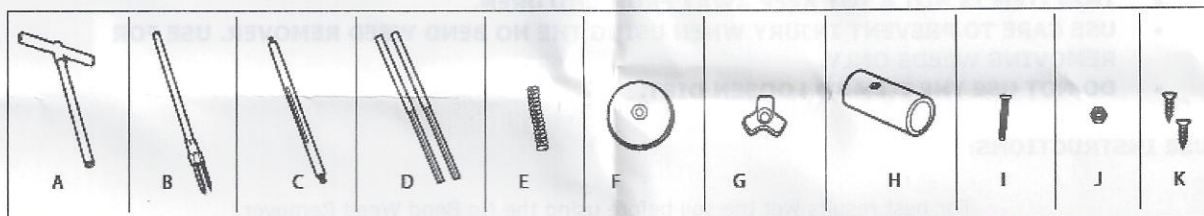

**A:** T-Shaped Handle  
**B:** 3 Prong Tube  
**C:** Slotted Ejector Tube

**D:** X2 Ejector Tubes  
**E:** Spring  
**F:** Rounded Cap

**G:** Ejector Cap  
**H:** Plastic Sleeve  
**I:** 1" L Screw

**J:** Hex Nut  
**K:** (x2) 3/4" L Screws

**ASSEMBLY INSTRUCTIONS:** (Reference illustration below)

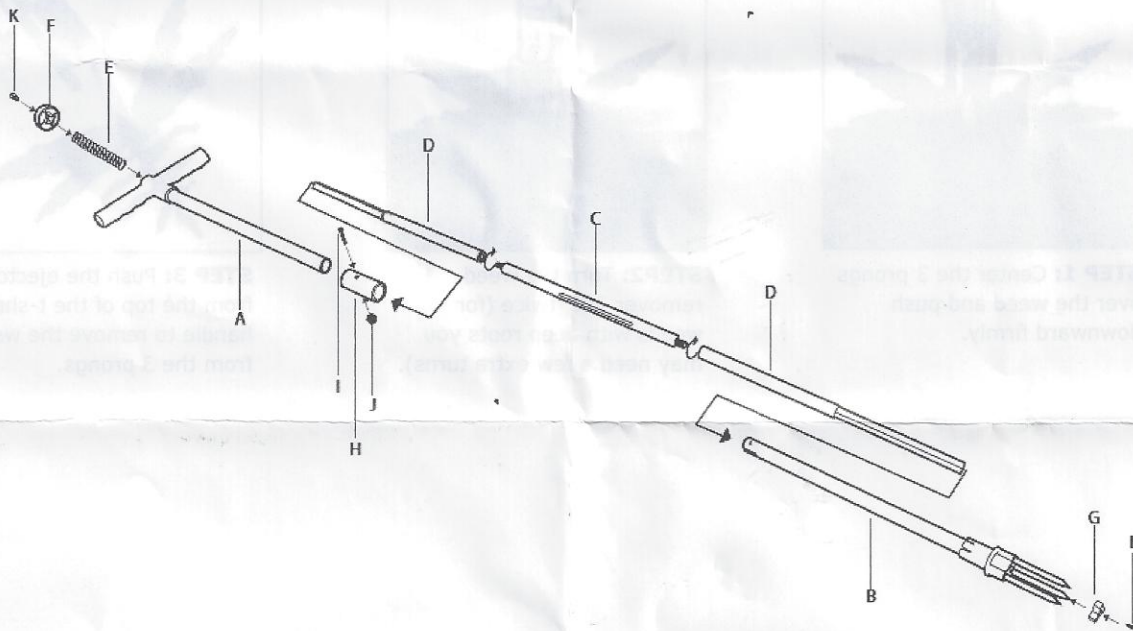

1. Thread an Ejector Tube (D) into each end of the Slotted Ejector Tube (C). Make sure the arrows embossed on the ends line up with each other.
2. The Slotted Ejector Tube (C) has letters embossed on each end (A & B). Insert the ejector tubes into the T-shaped Handle (A) with the letter B in first. Make sure the slot on Slotted Ejector Tube (C) is facing in the same directions as the screw holes on the end of the T-shaped Handle tube.
3. Slide the Spring (E) over the top part of the ejector tube (T-shaped Handle end).
4. Slide the Rounded Cap (F) over the top part of the ejector tube. Secure the round cap by threading a 3/4" L Screw (K) through the center of the rounded cap into the ejector tube.
5. Slide the Plastic Sleeve (H) over the ejector tube (opposite end of the round cap) onto the T-shaped Handle. Make sure the end with the wider slots (inside of sleeve) is inserted first.
6. Slide the 3 Prong Tube (B) over the ejector tube and connection point of the T-shaped Handle. Make sure the slots (opposite end of prongs) on the 3 prong tube line up with the compressed tubing sides on the connection point of the T-shaped handle. You may need to push firmly to assure all four holes line up (2 in front and 2 in back).
7. Place the Ejector Cap (G) with the flat surface facing outward over the ejector tube (in between the prongs) and secure it by threading in a 3/4" L Screw (K) through the ejector cap into the ejector tube.
8. Slide the Plastic Sleeve over the connection point of the t-shaped handle and the 3 prong tube. Make sure the holes line up on both sides.
9. Insert the Hex Nut (J) into the Plastic Sleeve (into hexagon shaped opening). Hold the hex nut with one hand as you thread the 1" L Screw (I) (through the Plastic Sleeve, T-shaped handle, and 3 prong tube) into the hex nut from the opposite end.

Manufactured for: Jobar International  
 Carson, CA. 90745



Made in China  
 10/12